

Please Approve this Drawing

Date	
Signature	

REVISIONS			
No.	DESCRIPTION	ECN NO.	DATE

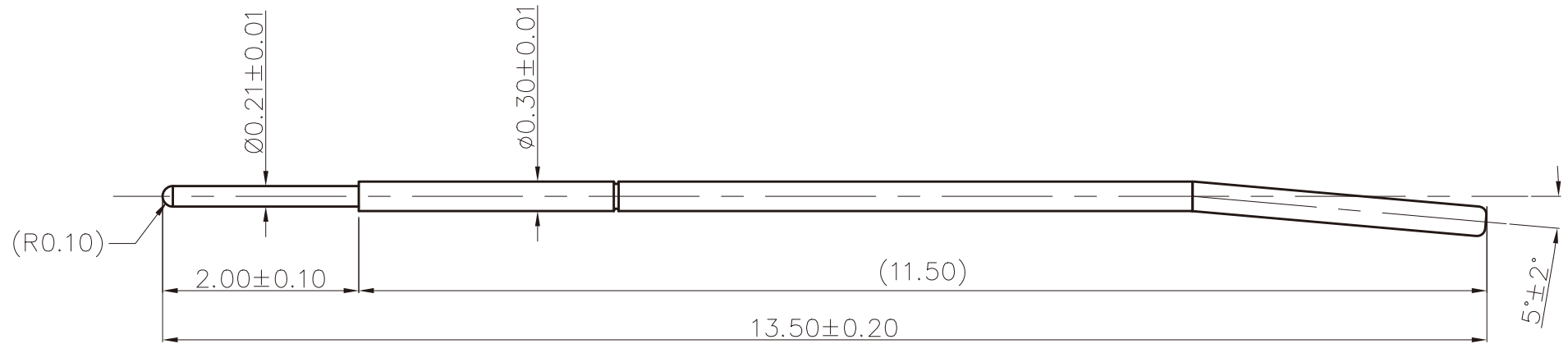

NOTE;

- Material
 - Plunger: SK4 2 micro-inch Au Plated
 - Barrel: PhBz Au Plated Flash
 - Spring: SWP Flash Au Plated
- Mechanical
 - Full stroke: 2.00 mm
 - Spring Force :15g $\pm 30\%$ at 1.33mm working stroke
- RoHS and HF compliant product.

DRAWN		SCALE:	8:1	UNIT	mm	DRAWING NO.	P-030D2L-0501
CHECKED		SHEET:	1 OF 1	PROJECT		TITLE. Test Probe	
APPROVED		DATE:	2012.08.30	VER.	D.0		
THE UNMARKED TOLERANCE ARE AS BELOW :						C.C.P. (DG) CONTACT PROBES CO.,LTD.	
LENGTH		ANGLE		东莞中探探针有限公司			
0~6.0	$\pm 0.05\text{mm}$	0.	$\pm 2.0'$	The information in this document is property of C.C.P company and should not be copied or reproduced in any other way, without written permission.			
>6~30	$\pm 0.10\text{ mm}$	0.0	$\pm 1.0'$				
>30~120	$\pm 0.15\text{mm}$	0.00	$\pm 0.50'$				