

4

3

2

1

REVISIONS

No.	DESCRIPTION	ECN No.	DATE
	INITIAL RELEASE	ECN-220130927	2013.09.28
△	Modify 2u" to 10u"	ECN-2201505049	2015.05.22

Please Approve this Drawing	
Date	
Signature	

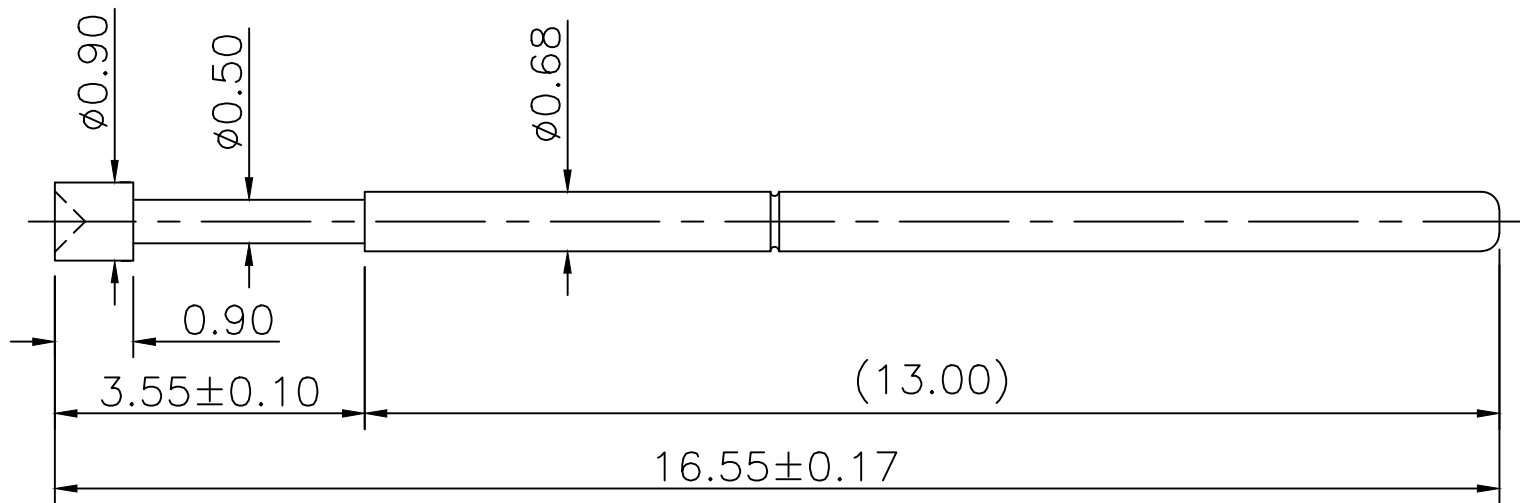

Notes:

- Material :
  - Plunger BeCu
  - Barrel PhBz
  - Spring SUS304
- Plating △
  - Plunger: 10 micro-inch min Au over 120~200 micro-inch Ni
  - Barrel: 2 micro-inch min Au over 40~80 micro-inch Ni
- Mechanical
  - Full Stroke : 2.65 mm
  - Spring Force: 80g±20% at 1.77 mm working stroke.
- Electrical:
  - Rated current & voltage: DC 12V; 1.5A
  - Contact resistance: 100 mohm Max at working stroke.
  - Durability: 100,000 cycles (minimum) at working stroke.
- Harmful material control please follow DOC. NO."DQ03050"

DRAWN	lin yu shou	SCALE:	8:1	UNIT	mm	DRAWING NO.	P-0A1-0512
CHECKED		SHEET:	1 OF 1	PROJECT		TITLE.	Test Probe
APPROVED		DATE:	2015.05.22	VER.	A.1		
THE UNMARKED TOLERANCE ARE AS BELOW :				<b>C.C.P. (DG) CONTACT PROBES CO.,LTD.</b> <b>东莞中探探针有限公司</b>			
LENGTH		ANGLE					
0~6.0	±0.05mm	0.	±2.0°	The information in this document is property of C.C.P company and should not be copied or reproduced in any other way, without written permission.			
>6~30	±0.10mm	0.0	±1.0°				
>30~120	±0.15mm	0.00	±0.50°				

4

3

2

1